

## GALLERY DESIGN SERIES

La grifería NK Compact, en acabado cromo, dispone de un regulador de agua oculto con caída en forma de cascada, lo que sin duda alguna le otorga una estética más uniforme y singular. La grifería de baño y ducha ofrece la posibilidad de adaptarse a diferentes espacios, gracias a su amplia variedad de modelos, siempre manteniendo un estudiado diseño.

*The chrome finished mixer line features an integrated cascade flow regulator that remarks the understated visual impact of its sleek.*

*The bath and shower mixer options boost an unseen talent for clever combinations. The collection consists of a complete program and is the ideal partner to blend into all kind of bathroom concepts.*

*La robinetterie NK Compact, aux finitions chromées, dispose d'un régulateur de débit dissimulé sous la chute d'eau en cascade ce qui lui confère indubitablement une esthétique plus uniforme et toute particulière. La robinetterie de bain et douche offre la possibilité de s'adapter à différentes ambiances grâce à sa vaste gamme de modèles, tout en maintenant un design soigné.*



Cromo  
Chrome  
Chromé

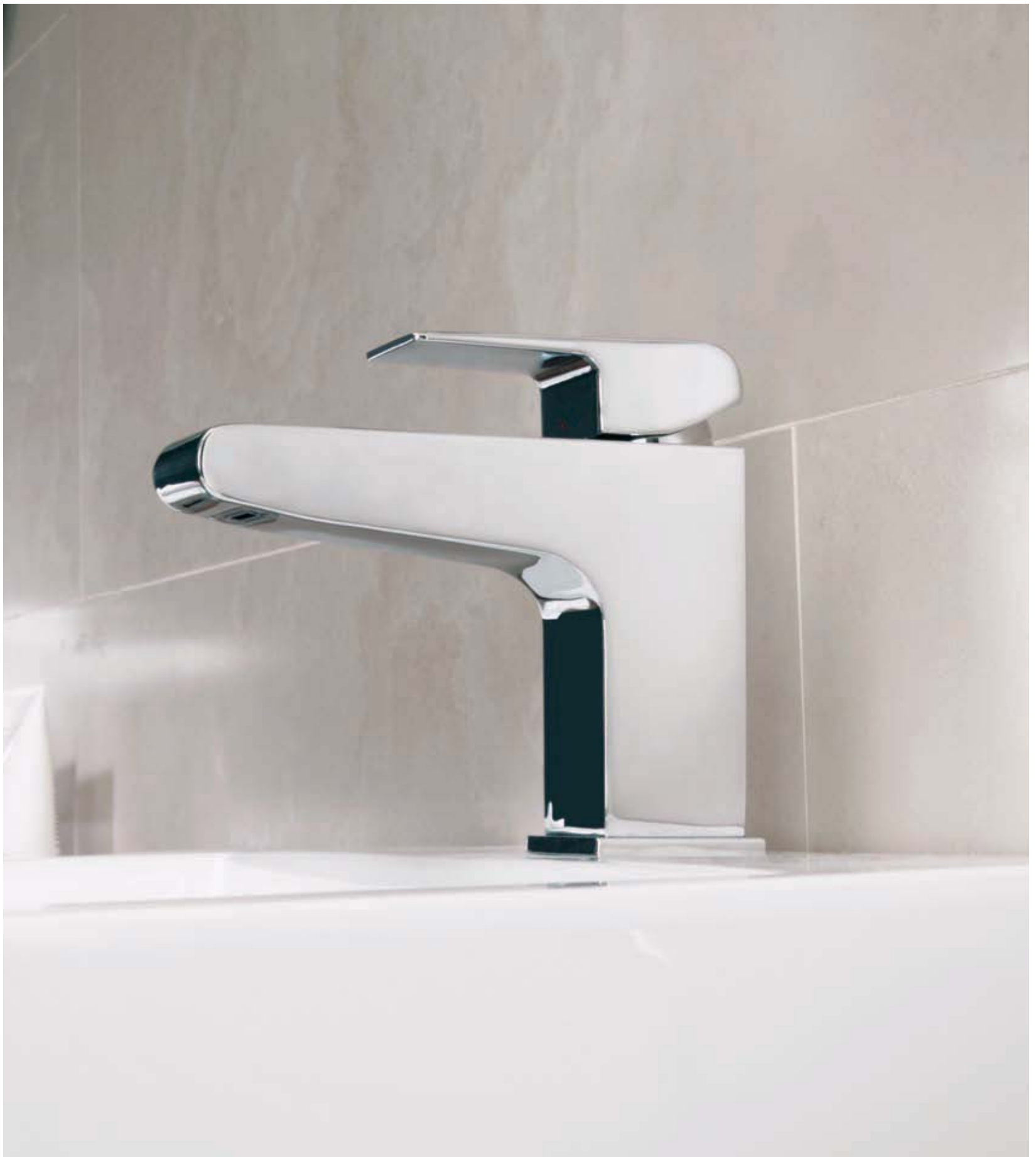

Nk Compact

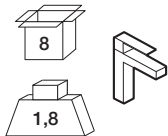

N140140006 | cromo  
100044768



Monomando lavabo con cartucho cerámico de Ø35 mm., conexiones de 3/8", una longitud de los latiguillos de 370 mm., con vaciador automático luxe y rompeaguas plano.

Single lever basin mixer with Ø35 mm. ceramic cartridge, 3/8" connections, 370 mm. long hoses, "luxe" pop-up waste set 1 1/4" and flat flowbreaker.

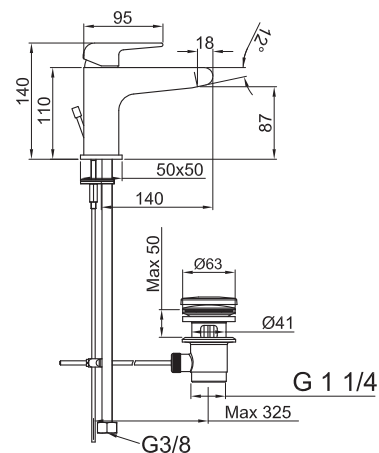

Mitigeur lavabo avec cartouche Ø35 mm. Flexibles raccords 3/8" longueur 370 mm. Garniture de vidage 1 1/4" "luxe". Bec avec brise-jet laminaire. Chute d'eau en effet cascade.

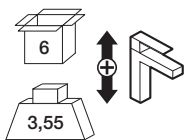

N146500702 | cromo  
100044769



Monomando lavabo caño alto con cartucho cerámico de Ø35 mm., conexiones de 3/8", una longitud de los latiguillos de 370 mm., con vaciador automático luxe y rompeaguas plano.

High spout single lever basin mixer with Ø35 mm. ceramic cartridge, 3/8" connections, 370 mm. long hoses, "luxe" pop-up waste set 1 1/4" and flat flowbreaker.

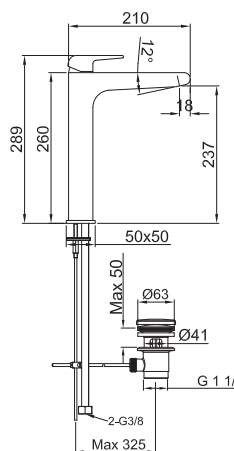

Mitigeur lavabo bec haut avec cartouche Ø35 mm. Flexibles raccords 3/8" longueur 370 mm. Garniture de vidage 1 1/4" "luxe". Bec avec brise-jet laminaire. Chute d'eau en effet cascade.

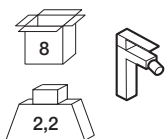

N140140005 | cromo  
100044770



Monomando bidé con cartucho cerámico de Ø35 mm., conexiones de 3/8", una longitud de los latiguillos 370 mm., con vaciador automático luxe y aireador "plus".

Single lever bidet mixer with Ø35 mm. ceramic cartridge, 3/8" connections, 370 mm. long hoses, "luxe" pop-up waste set 1 1/4" and "plus" aerator.

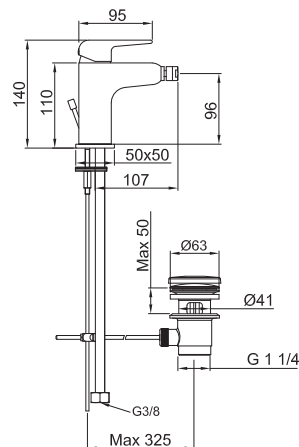

Mitigeur bidet avec cartouche Ø35 mm. Flexibles raccords 3/8" longueur 370 mm. Garniture de vidage 1 1/4" "luxe". Bec avec brise-jet laminaire. Chute d'eau en effet cascade.

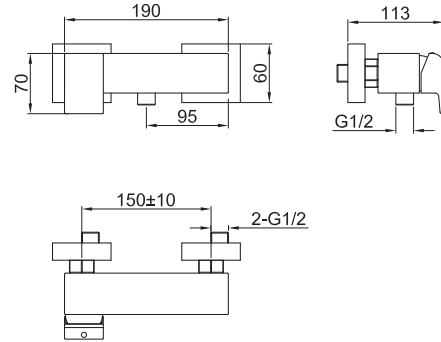
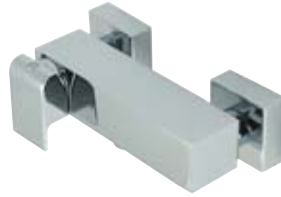
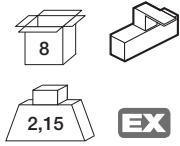

N139070905 | cromo  
100044772

Monomando externo ducha con cartucho cerámico de Ø35 mm. y conexiones de 1/2". Distancia excéntricas 150 +/-10 mm.

Wall mounted exposed shower mixer with Ø35 mm. ceramic cartridge and 1/2" connections. Centre distance 150 +/-10 mm.

Mitigeur externe douche avec cartouche Ø35 mm. Raccordements 1/2". Inverseur automatique. Bec avec brise-jet laminaire. Chute d'eau en effet cascade. Distance entre des raccords 150 +/-10 mm.

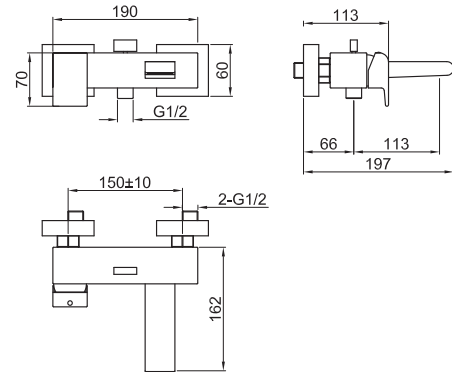
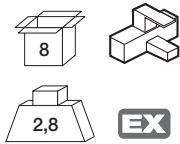

N139070904 | cromo  
100044771

Monomando externo baño/ducha con cartucho cerámico de Ø35 mm., conexiones de 1/2", inversor automático y rompeaguas plano. Distancia excéntricas 150 +/-10 mm.

Wall mounted exposed bath shower mixer with Ø35 mm. ceramic cartridge, 1/2" connections, automatic diverter and flat flowbreaker. Centre distance 150 +/-10 mm.

Mitigeur externe bain/douche avec cartouche Ø35 mm. Raccordements 1/2". Inverseur automatique. Bec avec brise-jet laminaire. Chute d'eau en effet cascade. Distance entre des raccords 150 +/-10 mm.

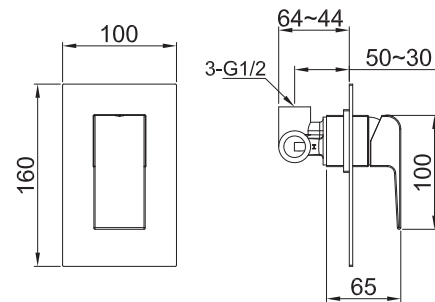
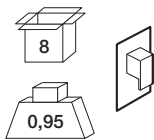

N173069906 | cromo  
100044774

Monomando encastre ducha con cartucho cerámico de Ø35 mm. y conexiones de 1/2". El caudal a 3 bares (con agua mezclada) es de 22,8 l/min.

Single lever concealed shower valve with Ø35 mm. ceramic cartridge and 1/2" connections. Flow rate at 3 bar (mixed water) 22,8 l/min.

Mitigeur douche à encastrer avec cartouche Ø35 mm. Raccordements 1/2". à 3 bars de pression (eau mélangée): 22,8 l/min.

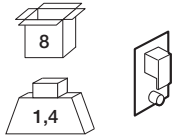

N173069905 | cromo  
100044773

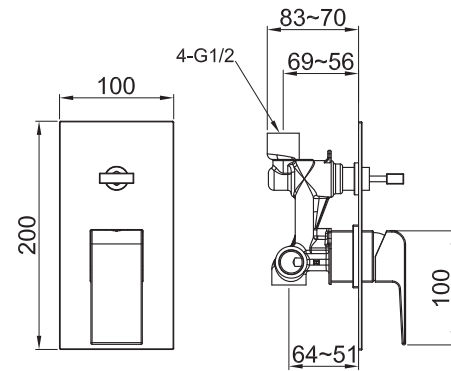

Monomando encastrado baño/ducha con cartucho cerámico de Ø35 mm., conexiones de 1/2" e inversor automático. El caudal a 3 bares (con agua mezclada) es de baño 19,8 l/min ducha 19,2 l/min.

Single lever concealed shower valve with diverter, Ø35 mm. ceramic cartridge, 1/2" connections and automatic diverter. Flow rate at 3 bar (mixed water) bath outlet: 19,8 l/min and shower outlet: 19,2 l/min.

Mitigeur bain/douche à encastrer avec cartouche Ø35 mm. Raccordements 1/2". Inverseur automatique. À 3 bars de pression (eau mélangée) pour bain: 19,8 l/min. Pour douche: 19,2 l/min.

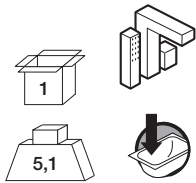

N160701303 | cromo  
100044775

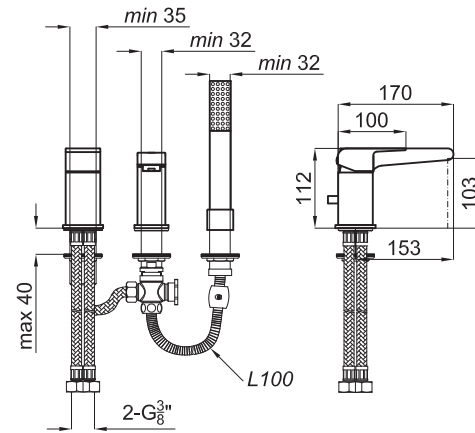

Batería instalación bañera 3 piezas. Incluye mando, caño bañera con inversor y maneta de ducha con flexo de 150 cm., conexiones de 3/8", y rompeaguas plano.

3 hole deck mounted bath set. Includes mixer, bath spout with diverter and hand shower with 150 cm. long shower flexible. 3/8" connections and flat flowbreaker.

Mitigeur bain/douche 3 pièces à poser sur baignoire. Flexibles raccordements 3/8". Douchette et flexible 150 cm. inclus. Bec avec inverseur et brise-jet laminaire. Chute d'eau en effet cascade.

