

GALLERY DESIGN SERIES

Combinar diseño y funcionalidad es el principal objetivo de la serie Libra. La forma elíptica de su cuerpo y la redondeada de su caño están culminados por una maneta de reducidas dimensiones en la versión monomando y por dos originales manetas ovaladas en su versión monoblock.

Changing the design and functionality is the main objective of the Libra series. The elliptical form of its body and the rounded form of its spout end in a small, cylindrical handle in its single-handle version, and in two original oval handles in its monoblock version.

Conjuguer design et fonctionnalité, tel est le principal objectif de la série Libra. La forme elliptique du corps et celle du bec arrondi sont couronnées par un levier cylindrique, aux dimensions réduites, pour la version mitigeur et par deux poignées originales de forme ovale pour la version mélangeur.



Cromo
Chrome
Chromé



Libra

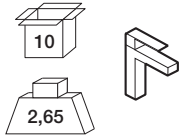

N160010001 | cromo
100038646

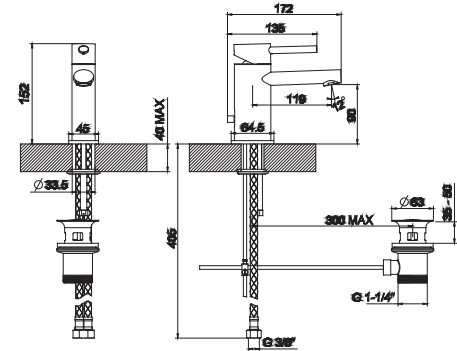

Monomando lavabo con cartucho cerámico de Ø25 mm. Conexiones de 3/8", una longitud de los latiguillos de 405 mm., con vaciador automático y aireador "plus".

Single lever basin mixer 3/8". Ø25 mm. + cartridge. Length of hoses 405 mm. With pop-up waste set 1 1/4". "Plus" aerator.

Mitigeur lavabo avec cartouche Ø25 mm. Flexibles raccordement 3/8" longueur 405 mm. Garniture de vidage 1 1/4". Avec mousseur "plus".

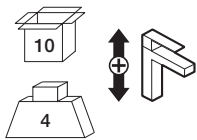

N160010301 | cromo
100038648

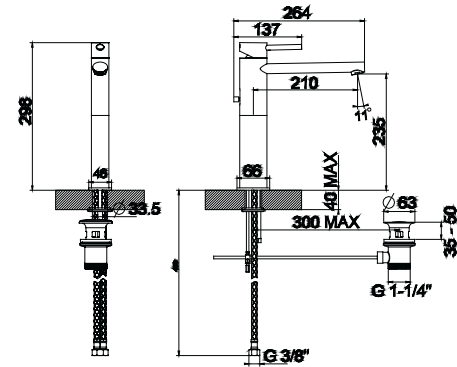

Monomando lavabo caño alto con cartucho cerámico de Ø25 mm. Conexiones de 3/8", una longitud de los latiguillos de 360 mm., con vaciador automático y aireador "plus".

High spout single lever basin mixer 3/8". Ø25 mm. ceramic cartridge. Length of hoses 360 mm. with pop-up waste set 1 1/4". "Plus" aerator.

Mitigeur lavabo bec haut avec cartouche Ø25 mm. Flexibles raccordement 3/8" longueur 360 mm. Garniture de vidage 1 1/4". Avec mousseur "plus".

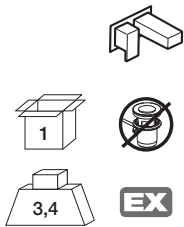

N160011301 | cromo
100038649

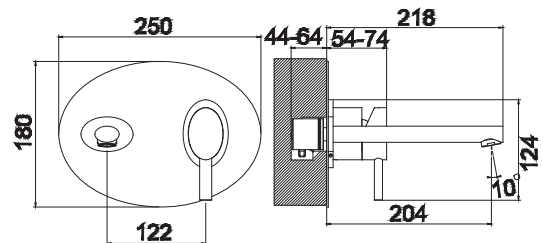
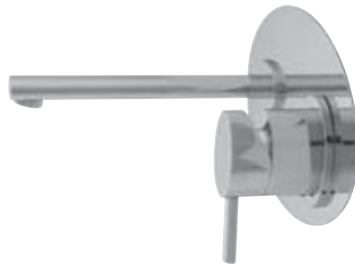

Monomando lavabo encastre con cartucho cerámico de Ø35 mm. Conexiones de 1/2", sin vaciador y aireador "plus".

Wall mounted basin mixer 1/2". Ø 35 mm. ceramic cartridge. Without pop-up waste. "Plus" aerator.

Mitigeur lavabo à encastrer avec cartouche Ø35 mm. Sans vidage. Avec mousseur "plus".

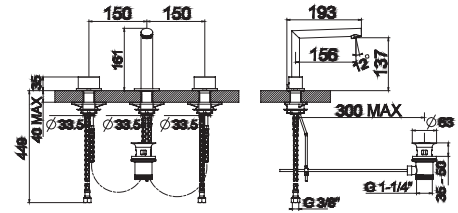
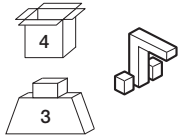

N160210001 | cromo
100038667

Batería lavabo 3 piezas con montura cerámica (apertura 90°). Conexiones de 3/8", una longitud de los latiguillos de 400 mm., con vaciador automático y aireador "plus".

3 hole basin mixer 3/8". ceramic disc valves (90°). With pop-up waste set 1 1/4". "Plus" aerator.

Mélangeur lavabo 3 pièces. Tête ceramique (ouverture 90°). Flexibles raccordement 3/8" longueur 400 mm. Garniture de vidage 1 1/4". Avec mousser "plus".

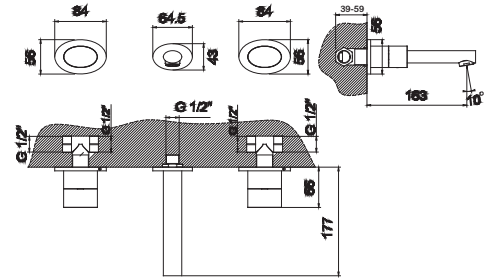
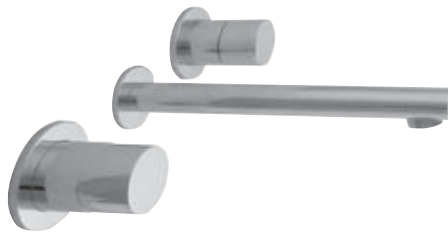
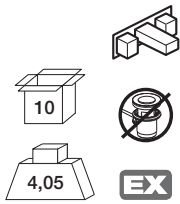

N160301301 | cromo
100038672

Batería lavabo encastre pared 3 piezas con montura cerámica (apertura 90°). Conexiones de 1/2", sin vaciador y aireador "plus".

Wall mounted basin mixer 1/2". Ceramic disc valves (90°). "Plus" aerator.

Mélangeur lavabo à encastrer 3 pièces. Tête ceramique (ouverture 90°). Sans vidage. Avec mousser "plus".

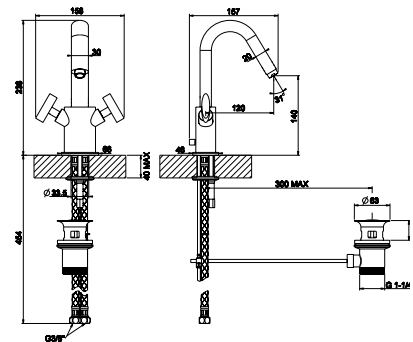
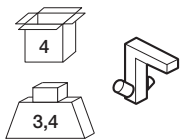

N160110001 | cromo
100038663

Monoblock lavabo con montura cerámica (apertura 90°). Conexiones de 3/8", una longitud de los latiguillos de 454 mm., con vaciador automático y aireador "plus".

Monoblock basin mixer 3/8". ceramic disc valves (apertura 90°). Length of hoses 454 mm. With pop-up waste set 1 1/4". "Plus" aerator.

Mélangeur lavabo tête ceramique (ouverture 90°). Flexibles raccordement 3/8" longueur 454 mm. Garniture de vidage 1 1/4". Avec mousser "plus".

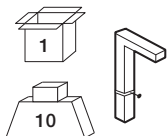

N160680001 | cromo
100038685

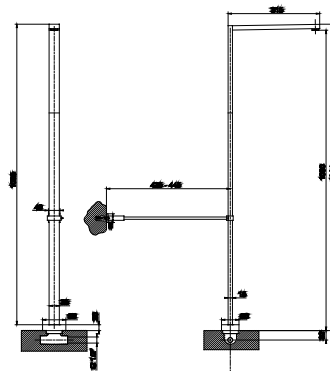

Boca lavabo instalación a pavimento. Conexiones de 1/2", sin vaciador y aireador "plus". Nota: incluye solo el caño. (1)

Floor mounted basin spout 1/2". "Plus" aerator. Consisting of: spout only. (1)

Bec lavabo installation au sol. Sans vidage. Avec mousseur "plus". Remarque: seulement bec inclus. (1)

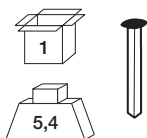

N160508501 | cromo
100038682

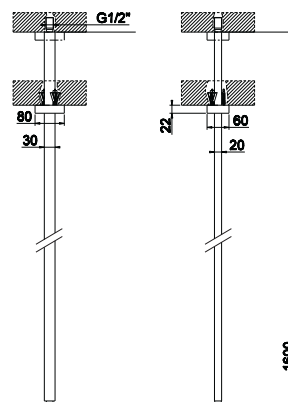

Boca lavabo instalación a techo. Conexiones de 1/2", sin vaciador y aireador "plus". Nota: incluye solo el caño. (1) (2)

Ceiling mounted basin spout 1/2". "Plus" aerator. Consisting of: spout only. (1) (2)

Bec lavabo installation au plafond. Sans vidage. Avec mousseur "plus". Remarque: seulement bec inclus. (1) (2)

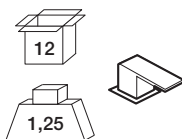

N160018001 | cromo
100038650

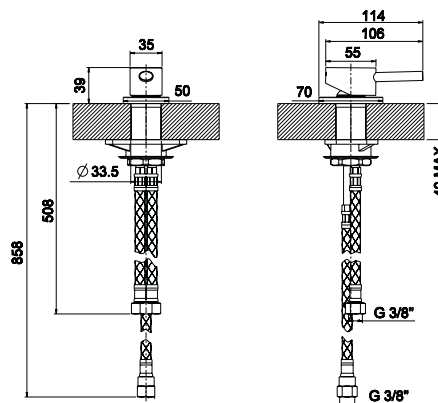

Monomando lavabo independiente con conexiones de 3/8" y sin vaciador.

Deck mounted control 3/8". Without pop-up waste.

Poignée mitigeur indépendante. Flexibles raccordement 3/8". À poser sur console.

(1) Para su funcionamiento es imprescindible pedir el monomando lavabo independiente

(1) For a correct use this item needs to be combined with a deck mounted control valve

(1) Pour une bonne utilisation il est indispensable de commander la poignée mitigeur indépendante

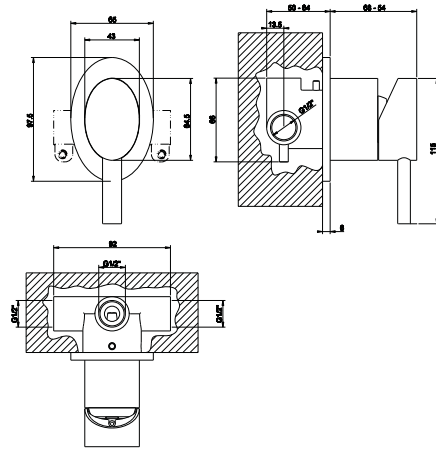
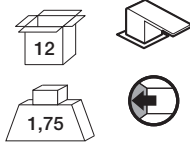

N160118001 | cromo
100046320

Monomando lavabo independiente instalación pared. Conexiones de 1/2" y sin vaciador.

Wall mounted control wall installation 1/2". Without pop-up waste.

Poignée mitigeur indépendante à encastrer. Raccordement 1/2".

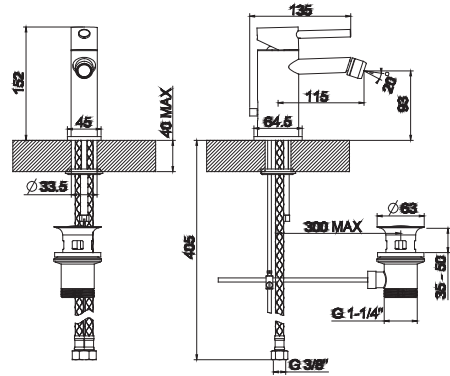
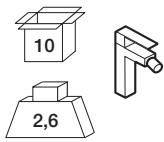

N160020001 | cromo
100038655

Monomando bidé con cartucho cerámico de Ø25 mm. Conexiones de 3/8", una longitud de los latiguillos de 405 mm., con vaciador automático y aireador "plus".

Single lever bidet mixer 3/8". Ø25 mm. ceramic cartridge. Length of hoses 405 mm. With pop-up waste set 1 1/4". "Plus" aerator.

Mitigeur bidet avec cartouche Ø25 mm. Flexibles raccordement 3/8" longueur 405 mm. Garniture de vidage 1 1/4". Avec mousseur "plus".

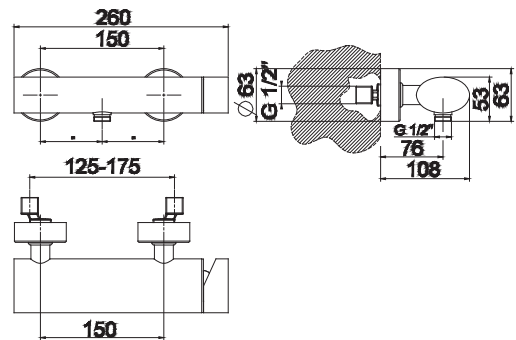
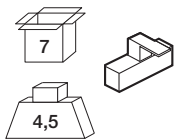

N160040801 | cromo
100038658

Monomando externo ducha con cartucho cerámico de Ø35 mm. Conexiones de 1/2". Distancia excéntricas 150 +/- 25 mm.

Wall mounted exposed shower mixer 1/2". Ø 35 mm. ceramic cartridge. Centre Distance 150 +/- 25 mm.

Mitigeur externe douche avec cartouche Ø35 mm. Distance entre des raccords 150 +/- 25 mm.

(2) Para medidas especiales el plazo es de 60 días.

(2) Delivery time of special sizes is 60 days

(2) Pour des dimensions spéciales, le délai est de 60 jours

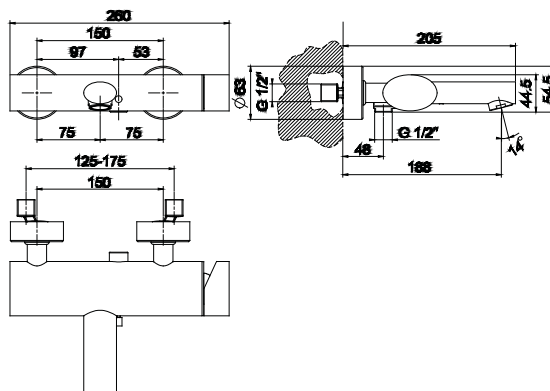
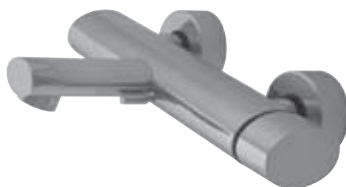
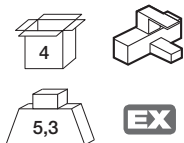

N160030801 | cromo
100038656

Monomando externo baño/ducha con cartucho cerámico de Ø35 mm. Conexiones de 1/2", inversor automático y aireador "plus". Distancia excéntricas 150 +/- 25 mm.

Wall mounted exposed bath shower mixer 1/2". Ø 35 mm. ceramic cartridge. Automatic diverter. "Plus" aerator. Centre Distance 150 +/- 25 mm.

Mitigeur externe bain/douche avec cartouche Ø35 mm. Inverseur automatique. Avec mousseur "plus". Distance entre des raccords 150 +/- 25 mm.

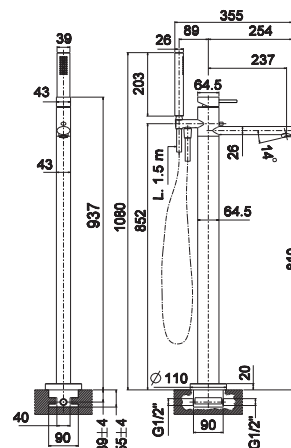
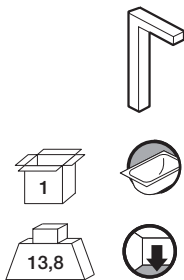

N160031501 | cromo
100038657

Monomando baño/ducha instalación a pavimento con cartucho cerámico de Ø35 mm. Conexiones de 1/2" y aireador "plus". Diámetro 90 mm. en la base.

Floor mounted bath shower mixer 1/2". Ø 35 mm. ceramic cartridge. Ø90 mm. "plus" aerator. at base.

Mitigeur bain/douche installation au sol avec cartouche Ø35 mm. Douchette, flexible et support inclus. Mousseur "plus" Ø90 mm. dans la base.

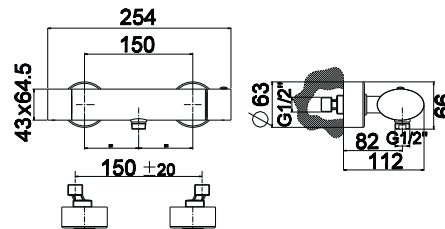
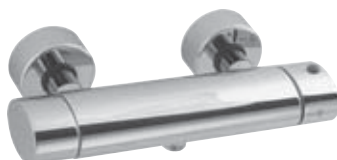
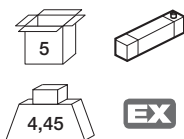

N160620801 | cromo
100038683

Termostática externo ducha con termoelemento de cera incorporado. Conexiones de 1/2". Incluye válvula anti retorno y stop de seguridad a 38°. Distancia excéntricas 150 +/- 20 mm.

Wall mounted exposed thermostatic shower mixer 1/2" with wax thermostatic element. Built in non-return valve. Safety stop at 38°C. Centre Distance 150 +/- 20 mm.

Thermostatique externe douche avec élément thermostatique compacte à cire. Clapets anti-retour incorporés. Poignée graduée à butée de sécurité à 38°C. Distance entre des raccords 150 +/- 20 mm.

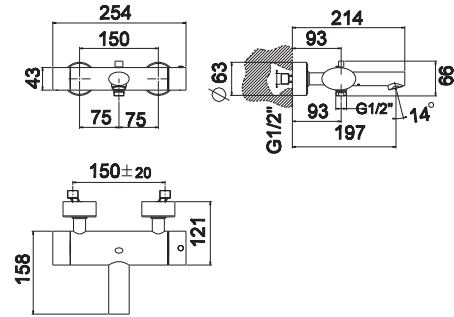
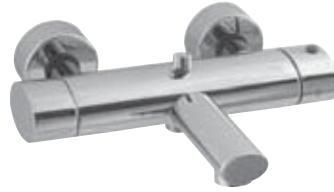
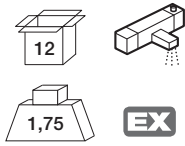

N160670801 | cromo
100038684

Termostática externo baño/ducha con termoelemento de cera incorporado. Conexiones de 1/2", inversor automático y aireador "plus". Incluye válvula anti retorno y stop de seguridad a 38°C.

Wall mounted exposed thermostatic bath shower mixer 1/2" with wax thermostatic element. automatic diverter. "Plus" aerator. Built in non-return valve. Safety stop at 38°C.

Thermostatique externe bain/douche avec élément thermostatique compacte à cire. Inverseur automatique. Avec mousseur "plus". Clapets anti-retour incorporés. Poignée graduée à butée de sécurité à 38°C.

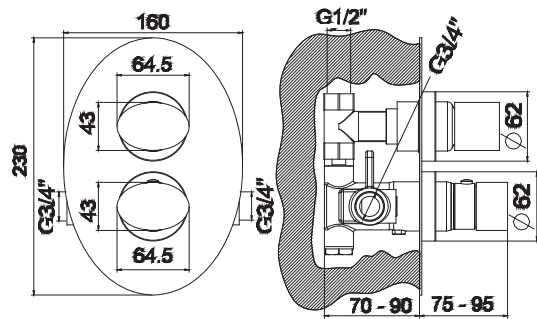
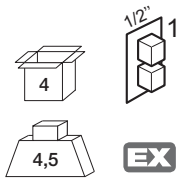

N160407701 | cromo
100038677

Termostática encastre 1 salida con termoelemento de cera incorporado. Conexiones de 1/2" - 3/4" según plano. El caudal a 3 bares (con agua mezclada) es de 18,2 l/min. Incluye válvula anti-retorno y stop de seguridad a 38°C.

Concealed thermostatic 1 way 1/2"-3/4" (like technical drawing) with wax thermostatic element. Flow rate 18,2 l/min at 3 bar. Built in non-return valve. Safety stop at 38°C

Thermostatique à encastre 3/4" 1 sortie 1/2" avec élément thermostatique compacte à cire. À 3 bars de pression (eau mélangée) 18,2 l/min. Clapets anti-retour incorporés. Poignée graduée à butée de sécurité à 38°C

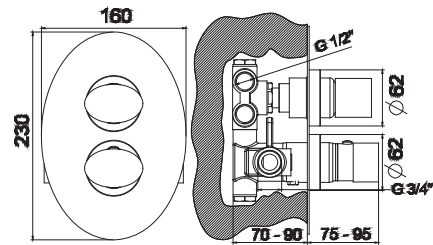
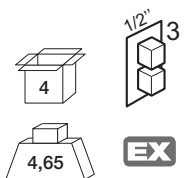

N160401701 | cromo
100038676

Termostática encastre 3 salidas con termoelemento de cera incorporado. Conexiones de 1/2" - 3/4" según plano. El caudal a 3 bares (con agua mezclada) es de 20 l/min. en una salida y 15 l/min. en las otras dos. Incluye válvula anti-retorno y stop de seguridad a 38°C.

Concealed thermostatic 3 ways 1/2"-3/4" (like technical drawing) with wax thermostatic element. Flow rate 20 l/min. at 3 bar (one outlet) and 15 l/min at 3 bar (two outlets). Built in non-return valve. Safety stop at 38°C.

Thermostatique à encastre 3/4" 3 sorties (1/2") avec élément thermostatique compacte à cire. À 3 bars de pression (eau mélangée) pour une sortie 20 l/min. Pour l'autre deux 15 l/min. Clapets anti-retour incorporés. Poignée graduée à butée de sécurité à 38°C.

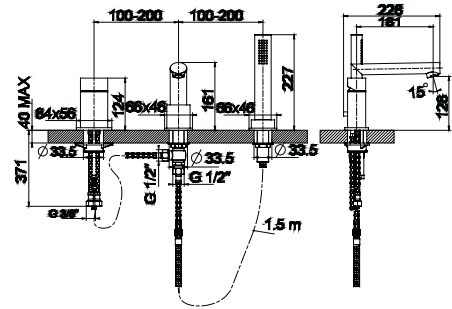
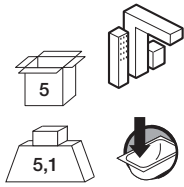

N160230101 | cromo
100038668

Batería instalación bañera 3 piezas. Incluye mando, caño bañera con inversor y maneta ducha con flexo de 150 cm. Conexiones de 3/8" y aireador "plus".

3 hole deck mounted bath set 3/8". Consisting of: handle, bath spout with diverter and hand shower with flexi shower de 150 cm. "Plus" aerator.

Mitigeur bain/douche 3 pièces. À poser sur baignoire. Douchette et flexible 150 cm. inclus. Bec avec inverseur et mousseur "plus". Flexibles raccordement 3/8".

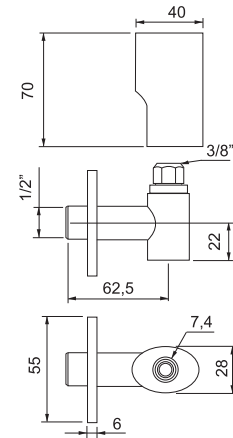
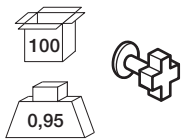

N160416501 | cromo
100038679

Llave de paso 1/2" encastre.

1/2" stop valve.

Robinet d'arrêt 1/2" à encastre.

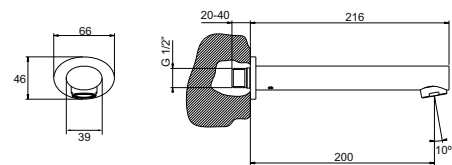
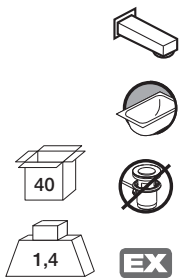

N160701301 | cromo
100038687

Caño bañera encastre con conexiones de 1/2" y aireador "plus".

Wall mounted bath spout 1/2". "Plus" aerator.

Bec mural pour baignoire avec mousseur "plus". Saillie 202 mm.

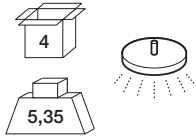

N160450001 | cromo
100038680

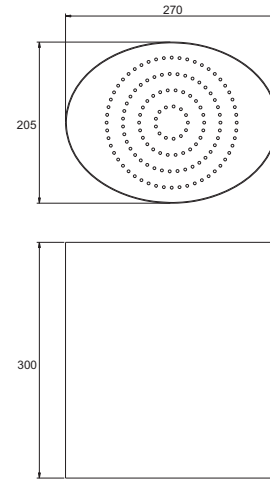

Rociador instalación a techo 30 cm.

Shower head.

Pomme de douche 30 cm.

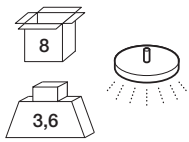

N160458501 | cromo
100038681

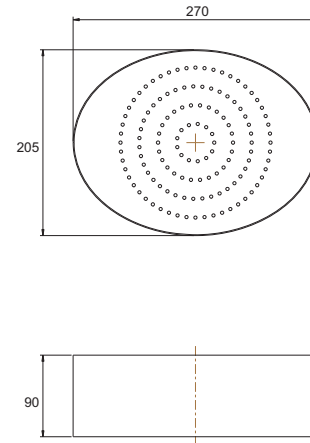

Rociador instalación a techo 9 cm.

Shower head.

Pomme de douche 9 cm.

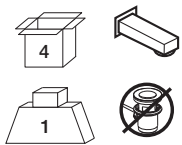

N160198201 | cromo
100038664

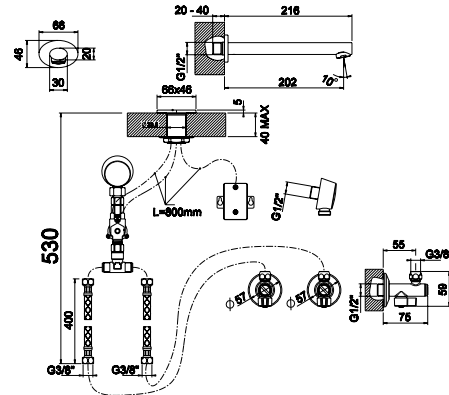

Caño lavabo encastre sensor con electroválvula. Conexiones de 1/2", sin vaciador y aireador "plus". Incluye sensor remoto independiente.

Spout with sensor control 1/2". Without pop-up waste. "Plus" aerator.

Bec lavabo à encastrer avec cellule infrarouge séparée. Raccordement 3/8". Sans vidage. Avec mousseur "plus". Cellule infrarouge inclus.

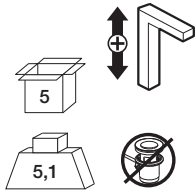

N160018201 | cromo
100038651

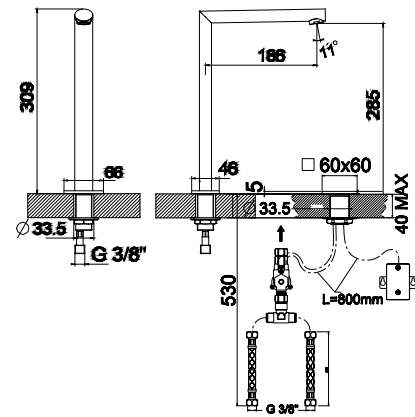

Caño alto con sensor remoto. Conexiones de 3/8", sin vaciador y aireador "plus". Incluye sensor remoto independiente.

High spout basin mixer with sensor control 3/8". "Plus" aerator.

Bec haut lavabo avec cellule infrarouge séparée. Raccordement 3/8" sans vidage. Avec mousser "plus". Cellule infrarouge inclus.



