

## GALLERY DESIGN SERIES

La serie Acro N, con sus formas netamente cuadradas y su aireador oculto, dar lugar a un diseño puro que sigue las últimas tendencias minimalistas. Hay que reseñar las propiedades antivandálicas del aireador oculto, así como la facilidad de limpieza por la ausencia de recovecos que la hacen ideal para lugares públicos.

*The Acro N Series, with its clearly square shapes and its concealed aerator, gives rise to a pure design which follows the latest minimalist tendencies. Worthy of special mention are the anti-vandalism properties of the concealed aerator as well as the ease of cleaning by the absence of nooks which make it ideal for public places.*

*La série Acro N avec ses formes nettement carrées et son aérateur dissimulé offre un design aux lignes pures qui suit les dernières tendances minimalistes. Il convient de souligner les propriétés anti-vandales de l'aérateur dissimulé de même que la facilité de nettoyage du fait de l'absence de recoins qui en font la solution idéale pour les lieux publics.*



Cromo  
Chrome  
Chromé



Acro N

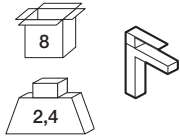

N172390005 | cromo  
100066961



Monomando lavabo con cartucho cerámico de Ø35 mm., conexiones de 3/8", una longitud de los latiguillos de 370 mm., con vaciador automático y aireador "plus".

Single lever basin mixer with Ø35 mm. ceramic cartridge, 3/8" connections, 370 mm. long hoses, pop-up waste set 1 1/4" and "plus" aerator.

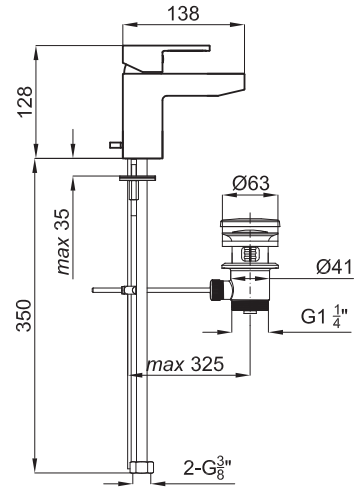

Mitigeur lavabo avec cartouche Ø35 mm. Flexibles raccordements 3/8" longueur 370 mm. Garniture de vidage 1 1/4". Mousseur "plus".

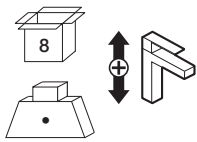

N272510111 | cromo  
100073413



Monomando lavabo caño alto con cartucho cerámico de Ø35 mm., conexiones de 3/8", una longitud de los latiguillos de 370 mm., con vaciador automático y aireador "plus".

High spout single lever basin mixer with Ø35 mm. ceramic cartridge, 3/8" connections, 370 mm. long hoses, pop-up waste set 1 1/4" and "plus" aerator.

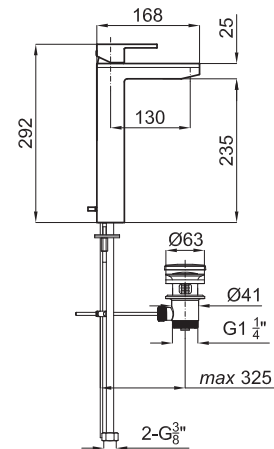

Mitigeur lavabo bec haut avec cartouche Ø35 mm. Flexibles raccordements 3/8" longueur 370 mm. Garniture de vidage 1 1/4". Mousseur "plus".

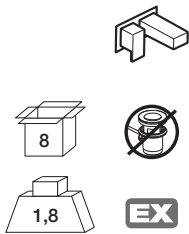

N172390006 | cromo  
100066984



Monomando lavabo encastre con cartucho cerámico de Ø35 mm., conexiones de 1/2", sin vaciador y con aireador "plus".

Wall mounted basin mixer with Ø35 mm. ceramic cartridge, 1/2" connections, without pop-up and with "plus" aerator.

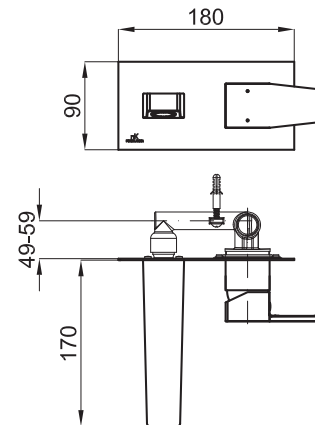

Mitigeur lavabo à encastrer avec cartouche Ø35 mm. Raccordements 1/2". Sans vidage. Avec mousseur "plus".

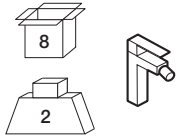

N172390007 | cromo  
100069049

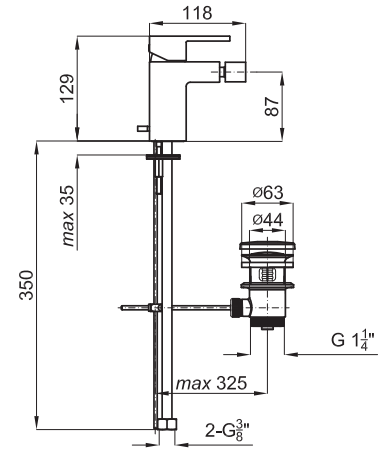

Monomando bidé con cartucho cerámico de Ø35 mm., conexiones de 3/8", una longitud de los latiguillos de 370 mm., con vaciador automático y aireador "plus".

Single lever bidet mixer with Ø35 mm. ceramic cartridge, 3/8" connections, 370 mm. long hoses, pop-up waste set 1 1/4" and "plus" aerator.

Mitigeur bidet avec cartouche Ø35 mm. Flexibles raccords 3/8" longueur 370 mm. Garniture de vidage 1 1/4". Mousseur "plus".

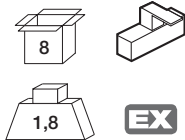

N172390008 | cromo  
100072077

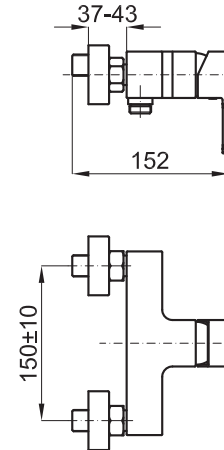

Monomando externo ducha con cartucho cerámico de Ø35 mm. y conexiones de 1/2". Distancia excéntricas 150 +/-15 mm.

Wall mounted exposed shower mixer with Ø35 mm. ceramic cartridge and 1/2" connections. Centre distance 150 +/-15 mm.

Mitigeur externe douche avec cartouche Ø35 mm. Raccords 1/2". Distance entre des raccords 150 +/-15 mm.

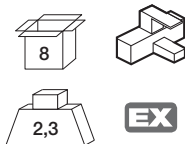

N172390010 | cromo  
100072094

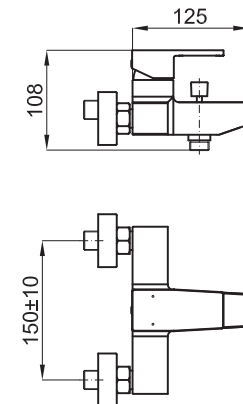
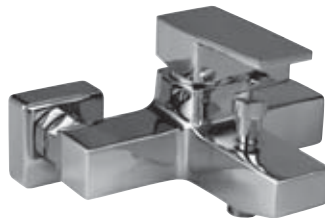

Monomando externo baño/ducha con cartucho cerámico de Ø35 mm., conexiones de 1/2", inversor semiautomático y aireador "plus". Distancia excéntricas 150 +/-15 mm.

Wall mounted exposed bath shower mixer with Ø35 mm. ceramic cartridge, 1/2" connections, semi-automatic diverter and "plus" aerator. Centre distance 150 +/-15 mm.

Mitigeur externe bain/douche avec cartouche Ø35 mm. Raccords 1/2". Inverseur semiautomatique. Mousseur "plus". Distance entre des raccords 150 +/-15 mm.

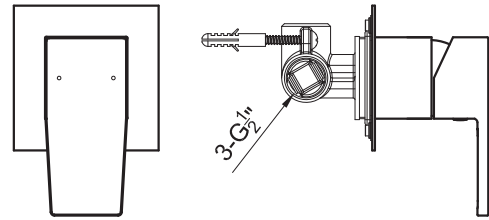
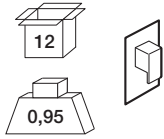

N172390012 | cromo  
100072706

Monomando encastre ducha con cartucho cerámico de Ø35 mm. y conexiones de 1/2". El caudal a 3 bares (con agua mezclada) es de 21,7 l/min.

Single lever concealed shower valve with Ø35 mm. ceramic cartridge and 1/2" connections. Flow rate at 3 bar (mixed water) 21,7 l/min.

Mitigeur douche à encastrer avec cartouche Ø35 mm. Raccordements 1/2". À 3 bars de pression (eau mélangée): 21,7 l/min.

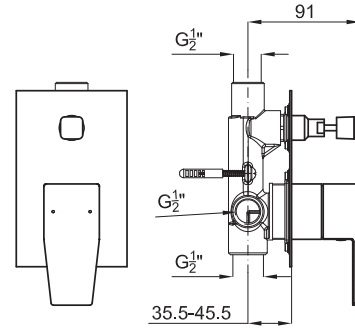
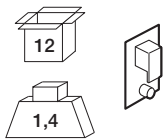

N172390013 | cromo  
100072705

Monomando encastre baño/ducha con cartucho cerámico de Ø35 mm., conexiones de 1/2" e inversor automático. El caudal a 3 bares (con agua mezclada) es de baño 20,3 l/min y de ducha 16,3 l/min.

Single lever concealed shower valve with diverter, Ø35 mm. ceramic cartridge, 1/2" connections and automatic diverter. Flow rate at 3 bar (mixed water) bath outlet: 20,3 l/min and shower outlet: 16,3 l/min.

Mitigeur bain/douche à encastrer avec cartouche Ø35 mm. Raccordements 1/2". inverseur automatique. À 3 bars de pression (eau mélangée) : pour bain 20,3 l/min. Pour douche: 16,3 l/min.

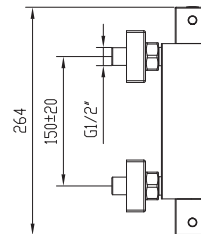
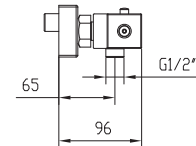
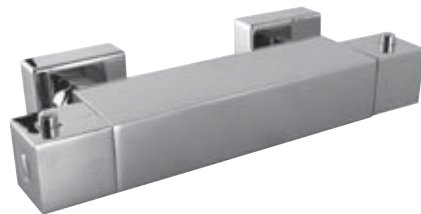
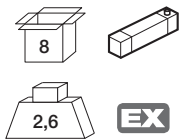

N172390001 | cromo  
100038886

Termostática externo ducha con termoelemento de cera incorporado. Conexiones de 1/2". Incluye válvula anti retorno, stop de seguridad a 38° y ECOSTOP. Distancia excéntricas 150 +/-20 mm.

Wall mounted exposed thermostatic bath shower mixer 1/2" with wax thermostatic element and "plus" aerator. Built in non-return valve. safety stop at 38°C and ECOSTOP button. Centre distance 150 +/-20 mm.

Thermostatique externe douche 1/2" avec élément thermostatique compacte à cire. Mousseur "plus". clapets anti-retour incorporés. poignée graduée à butée de sécurité à 38°C. Distance entre des raccords 150 +/- 20 mm. système ECOSTOP.

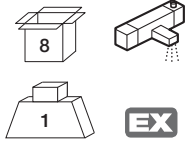

N172380001 | cromo  
100038885

Termostática externo baño/ducha con termoelemento de cera incorporado. Conexiones de 1/2", inversor regulador de caudal y aireador "plus". Incluye válvula anti retorno y stop de seguridad a 38°. Distancia excéntrica 150 +/- 20 mm.

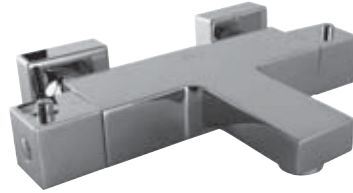

Wall mounted exposed thermostatic bath shower mixer with wax thermostatic element, 1/2" connections, shut-off diverter valve and "plus" aerator. Built in non-return valve. Safety stop at 38°C. Centre distance 150 +/- 20 mm.

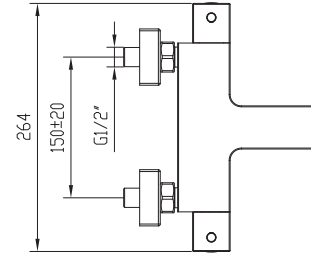
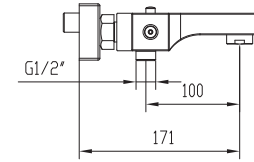

Thermostatique externe bain/douche 1/2" avec élément thermostatique compacte à cire. inverseur/régulateur de débit. Mousseur "plus". Clapets anti-retour incorporés. Poignée graduée à butée de sécurité à 38°C. Distance entre des raccords 150 +/- 20 mm.



## GALLERY DESIGN SERIES

La serie Acro Open incorpora en el mando un cómodo hueco que facilita su acceso y uso para todos los habitantes de la casa. Esta variación se ha realizado sin variar un ápice la identidad moderna y funcional que imbuye toda la serie.

*The Acro Open series includes a comfortable hole in the faucet handle that makes access and use easier for all members of the household. This variation was made without changing one bit the modern and functional identity that imbues the entire series.*

*La série Acro Open présente un levier de commande pratique avec un espace creux permettant un accès et une utilisation faciles à tous les membres de la maison. Cette variante a été introduite sans modifier pour autant l'identité moderne et fonctionnelle qui caractérise cette série.*

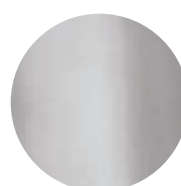

Cromo  
Chrome  
Chromé



Acro N open

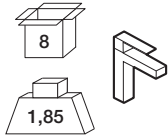

N182110302 | cromo  
100066962

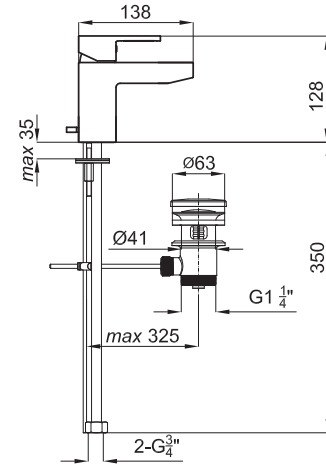

Monomando lavabo con cartucho cerámico de Ø35 mm., conexiones de 3/8", una longitud de los latiguillos de 370 mm., con vaciador automático y aireador "plus".

Single lever basin mixer with Ø35 mm. ceramic cartridge, 3/8" connections, 370 mm. long hoses, pop-up waste set 1 1/4" and "plus" aerator.

Mitigeur lavabo avec cartouche Ø35 mm. Flexibles raccords 3/8" longueur 370 mm. Garniture de vidage 1 1/4". Mousseur "plus".

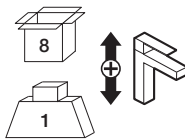

N272510112 | cromo  
100073414

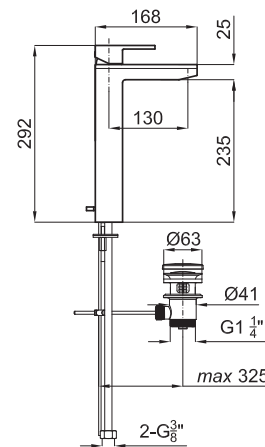

Monomando lavabo caño alto con cartucho cerámico de Ø35 mm., conexiones de 3/8", una longitud de los latiguillos de 370 mm., con vaciador automático y aireador "plus".

High spout single lever basin mixer with Ø35 mm. ceramic cartridge, 3/8" connections, 370 mm. long hoses, pop-up waste set 1 1/4" and "plus" aerator.

Mitigeur lavabo bec haut avec cartouche Ø35 mm. Flexibles raccords 3/8" longueur 370 mm. Garniture de vidage 1 1/4". Mousseur "plus".

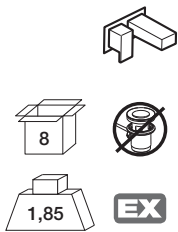

N182110303 | cromo  
100066983

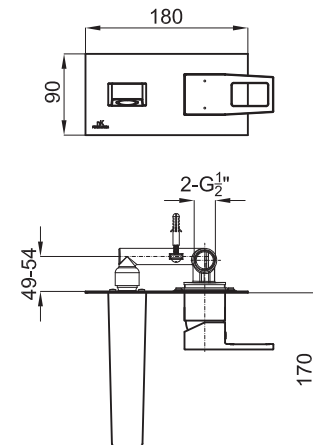

Monomando lavabo encastre con montura cerámica, conexiones de 1/2", sin vaciador y con aireador "plus".

Wall mounted basin mixer with Ø35 mm. ceramic cartridge, 1/2" connections, without pop-up and with "plus" aerator.

Mitigeur lavabo à encastrer avec cartouche Ø35 mm. Raccords 1/2". Sans vidage. Avec mousseur "plus".

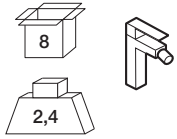

N182110304 | cromo  
100069050

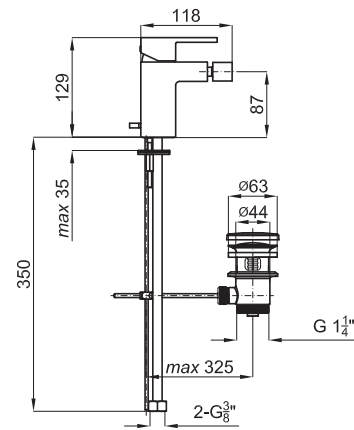

Monomando bidé con cartucho cerámico de Ø35 mm., conexiones de 3/8", una longitud de los latiguillos de 370 mm., con vaciador automático y aireador "plus".

Single lever bidet mixer with Ø35 mm. ceramic cartridge, 3/8" connections, 370 mm. long hoses, pop-up waste set 1 1/4" and "plus" aerator.

Mitigeur bidet avec cartouche Ø35 mm. Flexibles raccordements 3/8" longueur 370 mm. Garniture de vidage 1 1/4". Mousseur "plus".

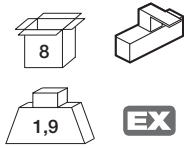

N172390009 | cromo  
100072093

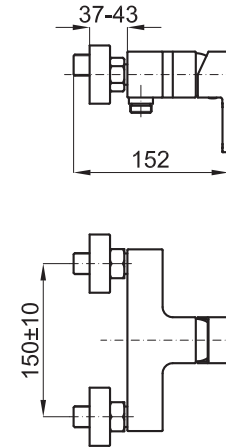
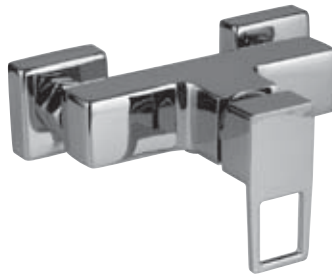

Monomando externo ducha con cartucho cerámico de Ø35 mm. y conexiones de 1/2". Distancia excéntricas 150 +/-15 mm.

Wall mounted exposed shower mixer with Ø35 mm. ceramic cartridge and 1/2" connections. Centre distance 150 +/-15 mm.

Mitigeur externe douche avec cartouche Ø35 mm. Raccordements 1/2". Distance entre des raccords 150 +/-15 mm.

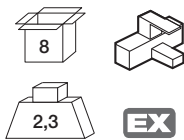

N182110305 | cromo  
100072092

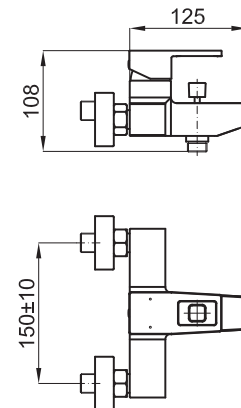
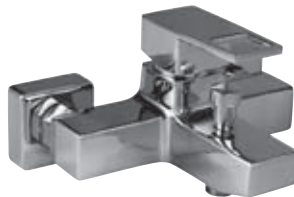

Monomando externo baño/ducha con cartucho cerámico de Ø35 mm., conexiones de 1/2", inversor semiautomático y aireador "plus". Distancia excéntricas 150+/-15 mm.

Wall mounted exposed bath shower mixer with Ø35 mm. ceramic cartridge, 1/2" connections, semi-automatic diverter and "plus" aerator. Centre distance 150+/-15 mm.

Mitigeur externe bain/douche avec cartouche Ø35 mm. Raccordements 1/2". inverseur semiautomatique. Mousseur "plus". Distance entre des raccords 150+/-15 mm.

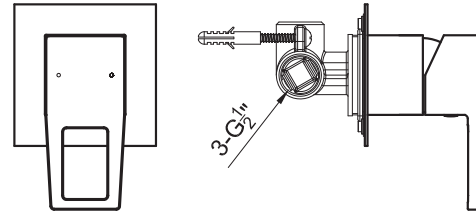
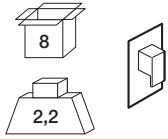

N172390011 | cromo  
100072708

Monomando encastre ducha con cartucho cerámico de Ø35 mm. y conexiones de 1/2". El caudal a 3 bares (con agua mezclada) es de 21,7 l/min.

Single lever concealed shower valve with Ø35 mm. cartridge and 1/2" connections. Flow rate at 3 bar (mixed water) 21,7 l/min.

Mitigeur douche à encastrer avec cartouche Ø35 mm. Raccordements 1/2". À 3 bars de pression (eau mélangée): 21,7 l/min.

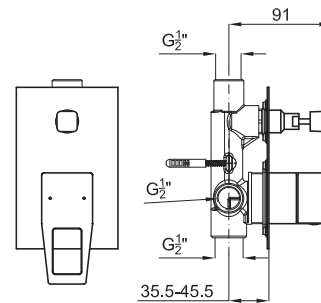
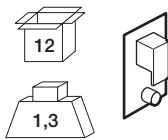

N172390014 | cromo  
100072707

Monomando encastre baño/ducha con cartucho cerámico de Ø35 mm., conexiones de 1/2" e inversor automático. El caudal a 3 bares (con agua mezclada) es de baño 20,3 l/min y de ducha 16,3 l/min.

Single lever concealed shower valve with diverter, Ø35 mm. ceramic cartridge, 1/2" connections and automatic diverter. Flow rate at 3 bar (mixed water) bath outlet: 20,3 l/min and shower outlet: 16,3 l/min.

Mitigeur bain/douche à encastrer avec cartouche Ø35 mm. Raccordements 1/2". Inverseur automatique. À 3 bars de pression (eau mélangée) : pour bain 20,3 l/min. Pour douche: 16,3 l/min.

